

ADDENDUM FOR LV SERIES IOM

MANUAL (PART# 8 733 822 471 Initial Release 8-18)

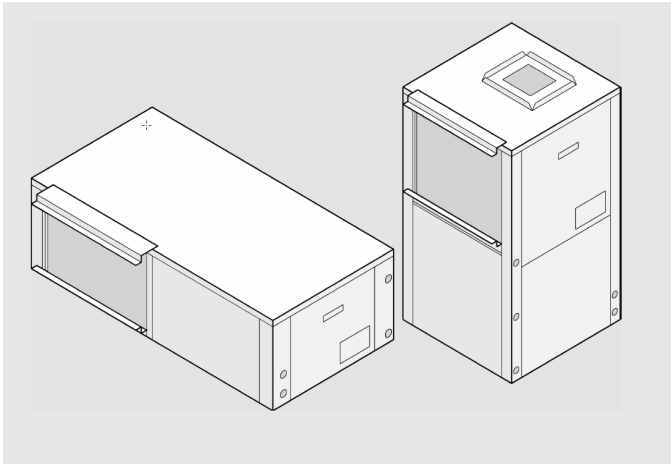

Figure #1 – VT and HZ LV Models

TABLE OF CONTENTS

Model Nomenclature.....1
 About the Addendum.....1
 General Description.....1
 Certified Performance.....2-3
 Electrical Data Tables.....3-5
 Pressure Temp.....6-7
 Horizontal Cabinet Effects.....8
 Overload Setting Verification.....9
 Notes.....10-12

MODEL NOMENCLATURE

	1	3	6	7	8	10	11	12	13	14	15	16	17
	1-2	3-5	6	7	8-9	10	11	12	13	14	15	16	17
	LV	18-	1	VT	C	-	F	L	T	P	U	D	
Revision Level	←												
A - Current													
C - Current													
D - Current													
	1	3	6	7	8	10	11	12	13	14	15	16	17
	1-2	3-5	6	7	8-9	10	11	12	13	14	15	16	17
	LV	24-	1	VT	C	-	F	L	T	P	U	D	
Revision Level	←												
A - Current													
C - Current													
D - Current													
	1	3	6	7	8	10	11	12	13	14	15	16	17
	1-2	3-5	6	7	8-9	10	11	12	13	14	15	16	17
	LV	30-	1	VT	C	-	F	L	T	P	U	D	
Revision Level	←												
A - Current													
C - Current													
D - Current													
	1	3	6	7	8	10	11	12	13	14	15	16	17
	1-2	3-5	6	7	8-9	10	11	12	13	14	15	16	17
	LV	36-	1	VT	C	-	F	L	T	P	U	D	
Revision Level	←												
A - Current													
C - Current													
D - Current													

ABOUT THE ADDENDUM

This addendum intention is to provide information on changes to the LV018, 024, 030 & 036 models, highlighting only the difference from current LV018, 024, 030 & 036 models; where applicable, with reference to the main LV IM (P/N 8733944336).



LV018, 024, 030, 036 are no longer available with Bristol Compressors.

GENERAL DESCRIPTION

The compressor on 018 models will change from a reciprocating compressor to a rotary compressor. This change will take place on -1 (208/230V 1Ph) and -2 (265 1Ph) and will apply only to units under new “D” revision.

The compressor on 024 models will change from a reciprocating compressor to a scroll compressor. This change will take place on -1 (208/230V 1Ph) and -2 (265 1Ph) -3 (208/230V 3Ph) and -4 (460V 3Ph) and will apply only to units under new “D” revision.

The compressor on 030 models will change from a reciprocating compressor to a scroll compressor. This change will take place on -1 (208/230V 1Ph) and -2 (265 1Ph) -3 (208/230V 3Ph) and -4 (460V 3Ph) and will apply only to units under new “D” revision.

The compressor on 036 models will change from a reciprocating compressor to a scroll compressor. This change will take place on -1 (208/230V 1Ph) and -2 (265 1Ph) -3 (208/230V 3Ph) and -4 (460V 3Ph) and will apply only to units under new “D” revision.

This addendum provides updated production information for this LV model, capacities 018, 024, 030, 036:

- Certified Performance
- Electrical Data Tables
- Pressure Temp Table

CERTIFIED PERFORMANCE

LV Series AHRI Ratings														
Unit Characteristics						Water Loop Heat Pump				Ground Loop Heat Pump				
						Cooling 86 deg. F		Heating 68 deg. F		Cooling 77 deg. F		Heating 32 deg. F		
Series	Application	Motor Option	Water coil	Model	Rev	Cooling Capacity	EER	Heating Capacity	COP	Cooling Capacity	EER	Heating Capacity	COP	
LV	TXV/EXT	PSC	Copper	007	C	6,100	13.20	7,800	5.10	6,800	15.10	4,900	3.40	
	TXV/EXT	PSC	Copper	009	C	8,200	12.40	9,900	4.70	8,700	14.60	5,700	3.20	
	TXV/EXT	PSC	Copper	012	C	10,900	12.20	13,000	4.30	11,800	14.10	8,700	3.20	
	TXV/EXT	PSC	Copper	015	C	14,200	12.80	16,100	4.40	14,200	14.60	11,300	3.30	
	TXV/EXT	PSC	Copper	018	D	18,200	14.10	20,200	4.60	19,200	16.15	14,300	3.50	
	TXV/EXT	PSC	Copper	024	D	24,300	14.20	27,400	5.00	25,400	16.90	18,100	3.55	
	TXV/EXT	PSC	Copper	030	D	28,200	13.40	32,600	4.70	29,500	15.60	21,500	3.40	
	TXV/EXT	PSC	Copper	036	D	36,900	14.30	38,800	4.65	38,500	16.65	27,100	3.55	
	TXV/EXT	PSC	Copper	060	B	NA	NA	NA	NA	NA	NA	NA	NA	NA
	TXV/EXT	PSC	Copper	060 VT	C	59,100	13.60	77,800	4.80	61,600	15.80	53,400	3.75	
TXV/EXT	PSC	Copper	070	B	64,000	13.30	72,800	4.40	66,400	15.00	50,800	3.40		
LV	TXV/EXT	ECM	Copper	015	C	13,700	13.90	15,500	4.40	14,400	16.20	10,700	3.30	
	TXV/EXT	ECM	Copper	018	D	18,500	14.50	19,900	4.70	19,500	16.95	14,000	3.55	
	TXV/EXT	ECM	Copper	024	D	24,700	14.90	27,000	5.10	25,800	17.65	17,700	3.60	
	TXV/EXT	ECM	Copper	030	D	28,800	13.50	32,000	4.90	30,100	15.65	20,900	3.55	
	TXV/EXT	ECM	Copper	036	D	37,200	14.70	38,400	4.75	38,800	17.10	26,700	3.60	
	TXV/EXT	ECM	Copper	060	B	59,000	14.30	66,400	4.30	61,100	16.40	46,200	3.30	
	TXV/EXT	ECM	Copper	060 VT	C	59,600	14.40	77,000	4.95	62,200	16.55	52,400	3.90	
	TXV/EXT	ECM	Copper	070	B	65,200	14.60	71,800	4.60	67,600	16.60	50,000	3.50	
LV	Captube	PSC	Copper	007	C	6,100	12.20	7,800	5.30	N/A				
	Captube	PSC	Copper	009	C	8,200	12.40	9,900	4.70					
	Captube	PSC	Copper	012	C	10,900	12.20	13,000	4.30					
	Captube	PSC	Copper	015	C	14,200	12.80	16,100	4.30					
	Captube	PSC	Copper	060 VT	C	59,100	13.60	77,800	4.80					
	Captube	PSC	Copper	070	B	64,000	13.30	72,800	4.40					
LV	Captube	ECM	Copper	015	C	13,700	13.90	15,500	4.40	N/A				
	Captube	ECM	Copper	060	B	59,000	14.30	66,400	4.30					
	Captube	ECM	Copper	060 VT	C	59,600	14.40	77,000	4.95					
	Captube	ECM	Copper	070	B	65,200	14.60	71,800	4.60					
LV	TXV/EXT	PSC	CuNi	007	C	6,100	13.10	7,800	5.00	6,800	15.10	4,900	3.40	
	TXV/EXT	PSC	CuNi	009	C	8,200	12.40	9,900	4.70	8,700	14.60	5,700	3.20	
	TXV/EXT	PSC	CuNi	012	C	10,900	12.20	13,000	4.30	11,800	14.10	8,700	3.20	
	TXV/EXT	PSC	CuNi	015	C	14,200	12.80	16,100	4.30	14,200	14.60	11,300	3.30	
	TXV/EXT	PSC	CuNi	018	D	18,100	13.70	20,300	4.60	19,100	15.85	14,000	3.55	
	TXV/EXT	PSC	CuNi	024	D	24,200	14.30	26,900	4.95	25,300	16.75	17,800	3.55	
	TXV/EXT	PSC	CuNi	030	D	27,900	13.25	31,800	4.70	29,200	15.60	21,100	3.40	
	TXV/EXT	PSC	CuNi	036	D	36,100	14.10	38,200	4.50	37,500	16.25	26,800	3.45	
	TXV/EXT	PSC	CuNi	060	B	NA	NA	NA	NA	NA	NA	NA	NA	
	TXV/EXT	PSC	CuNi	060 VT	C	59,100	13.60	77,800	4.80	61,600	15.80	53,400	3.75	
	TXV/EXT	PSC	CuNi	070	B	64,000	13.20	72,800	4.40	66,400	15.00	50,800	3.40	
LV	TXV/EXT	ECM	CuNi	015	C	13,700	13.90	15,500	4.40	14,400	16.20	10,700	3.30	
	TXV/EXT	ECM	CuNi	018	D	18,400	14.10	19,300	4.65	19,300	16.35	13,700	3.60	
	TXV/EXT	ECM	CuNi	024	D	24,600	14.60	26,500	5.05	25,700	17.15	17,400	3.60	
	TXV/EXT	ECM	CuNi	030	D	28,500	13.35	31,200	4.90	29,800	15.80	20,500	3.55	

	TXV/EXT	ECM	CuNi	036	D	36,400	14.50	37,800	4.60	37,800	16.70	26,400	3.50
	TXV/EXT	ECM	CuNi	060	B	59,000	14.30	66,400	4.30	61,100	16.40	46,200	3.30
	TXV/EXT	ECM	CuNi	060 VT	C	59,600	14.40	77,000	4.95	62,200	16.55	52,400	3.90
	TXV/EXT	ECM	CuNi	070	B	65,200	14.60	71,800	4.60	67,600	16.60	50,000	3.50
LV	Captube	PSC	CuNi	007	C	6,100	12.20	7,800	5.30	N/A			
	Captube	PSC	CuNi	009	C	8,200	12.40	9,900	4.70				
	Captube	PSC	CuNi	012	C	10,900	12.20	13,000	4.30				
	Captube	PSC	CuNi	015	C	14,200	12.80	16,100	4.30				
	Captube	PSC	CuNi	060 VT	C	59,100	13.60	77,800	4.80				
	Captube	PSC	CuNi	070	B	64,000	13.30	72,800	4.40				
LV	Captube	ECM	CuNi	015	C	13,700	13.90	15,500	4.40	N/A			
	Captube	ECM	CuNi	060	B	59,000	14.30	66,400	4.30				
	Captube	ECM	CuNi	060 VT	C	59,600	14.40	77,000	4.95				
	Captube	ECM	CuNi	070	B	65,200	14.60	71,800	4.55				

ELECTRICAL DATA TABLES

PSC Blower Motor											
Model	Voltage Code	Voltage/Hz/Phase	Voltage Min/Max	Compressor			Blower Motor			Min. Circuit Amps	MOP
				QTY	RLA	LRA	FLA	HP	Total Unit FLA		
LV018	1	208-230/1/60	197/253	1	7.4	33	1.8	0.25	9.2	11.1	15
	2	265/1/60	238/292	1	6	28	1.6	0.25	7.6	9.1	15
LV024	1	208-230/1/60	197/253	1	13.5	58.3	1.8	0.25	15.3	18.7	30
	2	265/1/60	238/292	1	9	54	1.6	0.25	10.6	12.9	20
	3	208-230/3/60	197/253	1	7.1	55.4	1.8	0.25	8.9	10.7	15
	4	460/3/60	414/506	1	3.5	28	0.9	0.25	4.4	5.3	15
LV030	1	208-230/1/60	197/253	1	12.8	64	1.8	0.25	14.6	17.8	30
	2	265/1/60	238/292	1	10.9	60	1.6	0.25	12.5	15.2	25
	3	208-230/3/60	197/253	1	8.3	58	1.8	0.25	10.1	12.2	20
	4	460/3/60	414/506	1	5.1	28	0.9	0.25	6	7.3	15
LV036	1	208-230/1/60	197/253	1	15.2	79	4.4	0.5	19.6	23.4	35
	2	265/1/60	238/292	1	11.6	72	3.3	0.5	14.9	17.8	25
	3	208-230/3/60	197/253	1	10.4	73	4.4	0.5	14.8	17.4	25
	4	460/3/60	414/506	1	5.8	38	1.8	0.5	7.6	9.1	15

X13 Blower Motor											
Model	Voltage Code	Voltage/Hz/Phase	Voltage Min/Max	Compressor			Blower Motor			Min. Circuit Amps	MOP
				Quantity	RLA	LRA	FLA	HP	Total Unit FLA		
LV018	1	208-230/1/60	197/253	1	7.4	33	2.8	0.33	10.2	12.1	15
	2	265/1/60	238/292	1	6	28	2.6	0.33	8.6	10.1	15
LV024	1	208-230/1/60	197/253	1	13.5	58.3	2.8	0.33	16.3	19.7	30
	2	265/1/60	238/292	1	9	54	2.6	0.33	11.6	13.9	20
	3	208-230/3/60	197/253	1	7.1	55.4	2.8	0.33	9.9	11.7	15
	4	460/3/60	414/506	1	3.5	28	2.1	0.5	5.6	6.5	15
LV030	1	208-230/1/60	197/253	1	12.8	64	2.8	0.33	15.6	18.8	30
	2	265/1/60	238/292	1	10.9	60	2.6	0.33	13.5	16.2	25
	3	208-230/3/60	197/253	1	8.3	58	2.8	0.33	11.1	13.2	20
	4	460/3/60	414/506	1	5.1	28	2.1	0.5	7.2	8.5	15
LV036	1	208-230/1/60	197/253	1	16.7	79	4.1	0.5	19.3	23.1	35
	2	265/1/60	238/292	1	11.6	72	3.6	0.5	15.2	18.1	25
	3	208-230/3/60	197/253	1	10.4	73	4.1	0.5	14.5	17.1	25
	4	460/3/60	414/506	1	5.8	38	2.1	0.5	7.9	9.4	15

EON Blower Motor											
Model	Voltage Code	Voltage/Hz/Phase	Voltage Min/Max	Compressor			Blower Motor			Min. Circuit Amps	MOP
				Quantity	RLA	LRA	FLA	HP	Total Unit FLA		
LV018	1	208-230/1/60	197/253	1	7.4	33	2.8	0.33	10.2	12.1	15
	2	265/1/60	238/292	1	6	28	2.6	0.33	8.6	10.1	15
LV024	1	208-230/1/60	197/253	1	13.5	58.3	2.8	0.33	16.3	19.7	30
	2	265/1/60	238/292	1	9	54	2.6	0.33	11.6	13.9	20
	3	208-230/3/60	197/253	1	7.1	55.4	2.8	0.33	9.9	11.7	15
	4	460/3/60	414/506	1	3.5	28	2.6	0.33	6.1	7.0	15
LV030	1	208-230/1/60	197/253	1	12.8	64	2.8	0.33	15.6	18.8	30
	2	265/1/60	238/292	1	10.9	60	2.6	0.33	13.5	16.2	25
	3	208-230/3/60	197/253	1	8.3	58	2.8	0.33	11.1	13.2	20
	4	460/3/60	414/506	1	5.1	28	2.6	0.33	7.7	9.0	15
LV036	1	208-230/1/60	197/253	1	15.2	79	4.3	0.5	19.5	23.3	35
	2	265/1/60	238/292	1	11.6	72	4.1	0.5	17.6	18.6	30
	3	208-230/3/60	197/253	1	10.4	73	4.3	0.5	14.7	17.3	25
	4	460/3/60	414/506	1	5.8	38	4.1	0.5	9.9	11.4	15

Compressor Characteristics			
MODEL	Voltage Code	Voltage/Hz/Phase	Run Capacitor (µF/V)
LV007 VT & CF	1	208-230/1/60	15/370
	2	265/1/60	15/440
LV007 HZ	1	208-230/1/60	15/370
	2	265/1/60	15/440
LV009 VT & CF	1	208-230/1/60	15/370
	2	265/1/60	10/440
LV009 HZ	1	208-230/1/60	15/370
	2	265/1/60	10/440
LV012 VT & CF	0	#N/A	35/370
	1	208-230/1/60	20/370
	2	265/1/60	15/440
LV012 HZ	0	#N/A	35/370
	1	208-230/1/60	20/370
	2	265/1/60	15/440
LV015	1	208-230/1/60	25/440
	2	265/1/60	15/440
LV018	1	208-230/1/60	30/370
	2	265/1/60	30/440
LV024	1	208-230/1/60	35/370
	1	208-230/1/60	35/370
	2	265/1/60	40/370
	3	208-230/1/60	-
	4	460/3/60	-
LV030	1	208-230/1/60	40/370
	1	208-230/1/60	40/370
	2	265/1/60	40/370
	3	208-230/1/60	-
	3	208-230/1/60	-
	4	460/3/60	-
LV036	1	208-230/1/60	45/370
	2	265/1/60	60/370
	3	208-230/1/60	-
	4	460/3/60	-
	4	460/3/60	-

PRESSURE TEMP

OPERATING DATA										
			Cooling				Heating			
Model	Enter Fluid Temp (°F)	Water Flow (GPM/Ton)	Suction Pressure (PSIG)	Discharge Pressure (PSIG)	Water Temp Rise °F	Air Temp Drop °F	Suction Pressure (PSIG)	Discharge Pressure (PSIG)	Water Temp Drop °F	Air Temp Rise °F
LV018	30	3					58-68	275-285	5-6	19-23
		5					62-72	280-290	3-4	20-24
	40	3	122-140	225-235	17-19	21-25	71-81	290-300	7-8	22-26
		5	120-138	197-207	10-12	22-26	77-87	296-306	4-5	23-27
	50	3	123-141	241-251	15-17	21-25	88-98	308-318	7-8	25-29
		5	122-140	219-229	9-11	21-25	95-105	315-325	4-5	27-31
	60	3	124-142	273-283	15-17	20-24	105-115	324-334	9-10	28-32
		5	123-141	251-261	9-11	21-25	114-124	331-341	5-6	30-34
	70	3	126-144	310-320	14-16	20-24	125-135	340-350	10-11	32-36
		5	125-143	287-297	8-10	20-24	135-145	348-358	6-7	33-37
	80	3	128-146	351-361	14-16	19-23	146-156	356-366	12-13	35-39
		5	127-145	328-338	8-10	20-24	159-169	366-376	7-8	37-41
	90	3	130-148	397-407	14-16	19-23	169-179	374-384	13-14	39-43
		5	129-147	373-383	8-10	19-23	186-196	386-396	8-9	41-45
	100	3	132-150	447-457	14-16	18-22				
		5	131-149	423-433	8-10	18-22				

OPERATING DATA										
			Cooling				Heating			
Model	Enter Fluid Temp (°F)	Water Flow (GPM/Ton)	Suction Pressure (PSIG)	Discharge Pressure (PSIG)	Water Temp Rise °F	Air Temp Drop °F	Suction Pressure (PSIG)	Discharge Pressure (PSIG)	Water Temp Drop °F	Air Temp Rise °F
LV024	30	4					69-79	276-296	7-8	19-23
		6					73-83	281-301	4-5	20-24
	40	4	123-140	216-234	17-19	22-26	83-93	291-311	8-9	22-26
		6	122-139	196-214	11-13	22-26	87-97	296-316	5-6	23-27
	50	4	124-141	234-252	15-17	21-25	100-110	310-330	9-10	25-29
		6	123-140	218-236	10-12	22-26	106-116	316-336	5-6	26-30
	60	4	126-143	269-287	15-17	21-25	118-128	329-349	10-11	28-32
		6	125-142	252-270	10-12	21-25	125-135	336-356	6-7	29-33
	70	4	128-145	307-325	15-17	20-24	139-149	347-367	12-13	31-35
		6	127-144	290-308	9-11	20-24	147-157	354-374	7-8	33-37
	80	4	130-147	349-367	14-16	19-23	160-170	364-384	14-15	35-39
		6	129-146	333-351	9-11	20-24	171-181	372-392	8-9	36-40
	90	4	132-149	396-414	14-16	19-23	185-195	382-402	16-17	38-42
		6	131-148	380-398	9-11	19-23	199-209	391-411	9-10	40-44
	100	4	134-151	449-467	14-16	18-22				
		6	133-150	432-450	9-11	18-22				

OPERATING DATA										
			Cooling				Heating			
Model	Enter Fluid Temp (°F)	Water Flow (GPM/Ton)	Suction Pressure (PSIG)	Discharge Pressure (PSIG)	Water Temp Rise °F	Air Temp Drop °F	Suction Pressure (PSIG)	Discharge Pressure (PSIG)	Water Temp Drop °F	Air Temp Rise °F
LV030	30	4					64-74	289-309	7-8	19-23
		7					70-80	295-315	4-5	20-24
	40	4	120-138	233-251	20-22	21-25	77-87	305-325	8-9	22-26
		7	118-136	200-218	11-13	22-26	84-94	314-334	5-6	23-27
	50	4	121-139	249-267	18-20	21-25	94-104	327-347	9-10	25-29
		7	120-138	223-241	10-12	21-25	103-113	336-356	5-6	27-31
	60	4	123-141	283-301	18-20	21-25	111-121	344-364	10-11	28-32
		7	122-140	257-275	10-12	21-25	122-132	354-374	6-7	30-34
	70	4	125-143	323-341	17-19	20-24	130-140	361-381	12-13	32-36
		7	123-141	295-313	10-12	20-24	143-153	373-393	7-8	34-38
	80	4	127-145	366-384	17-19	19-23	150-160	378-398	14-15	35-39
		7	126-144	341-359	9-11	19-23	167-177	392-412	8-9	38-42
	90	4	129-147	414-432	17-19	19-23	173-183	397-417	16-17	39-43
		7	128-146	388-406	9-11	19-23	193-203	413-433	9-10	41-45
	100	4	131-149	466-484	17-19	18-22				
		7	130-148	441-459	9-11	18-22				

OPERATING DATA										
			Cooling				Heating			
Model	Enter Fluid Temp (°F)	Water Flow (GPM/Ton)	Suction Pressure (PSIG)	Discharge Pressure (PSIG)	Water Temp Rise °F	Air Temp Drop °F	Suction Pressure (PSIG)	Discharge Pressure (PSIG)	Water Temp Drop °F	Air Temp Rise °F
LV036	30	4.5					60-70	278-298	7-8	17-21
		9					66-76	285-305	3-4	18-22
	40	4.5	119-135	226-250	23-25	22-26	72-82	292-312	9-10	19-23
		9	116-132	183-207	11-13	23-27	81-91	302-322	4-5	21-25
	50	4.5	121-137	259-283	22-24	21-25	86-96	308-328	10-11	22-26
		9	118-134	214-238	11-13	22-26	97-107	319-339	5-6	24-28
	60	4.5	123-139	295-319	22-24	21-25	101-111	323-343	12-13	25-29
		9	120-136	248-272	11-13	21-25	115-125	335-355	6-7	27-31
	70	4.5	124-140	335-359	22-24	20-24	117-127	337-357	14-15	28-32
		9	122-138	285-309	10-12	21-25	135-145	352-372	7-8	31-35
	80	4.5	126-142	378-402	21-23	20-24	135-145	352-372	16-17	31-35
		9	124-140	327-351	10-12	20-24	157-167	370-390	8-9	34-38
	90	4.5	128-144	425-449	20-22	19-23	155-165	369-389	17-18	34-38
		9	126-142	372-396	10-12	20-24	181-191	390-410	9-10	38-42
	100	4.5	130-146	477-501	20-22	19-23				
		9	128-144	423-447	10-12	19-23				

HORIZONTAL CABINET EFFECTS:

Horizontal Unit Dimensions																		
Overall unit dimensions do not include filter rack or duct flanges.																		
Model	A	B	C	D	E	F	G	H	J	K	M	N	P	Q	R	T	Condenser Water Connections	Recommended Replacement Nominal Filter Size
	Width	Depth	Height	Cabinet End to Filter Rack	R/A Duct Width	Cab Front to Filter Rack	Water Inlet	Water Outlet	Side to Discharge (End)	Discharge Width	Top to Discharge (FLE & FRS)	Discharge Height	End to Discharge (Straight)	Top to Discharge (FRE & FLS)	Filter Rack Height	R/A Duct Flange Height		
LV024	22.0	43.0	18.0	1.5	25.0	16.5	2.86	14.13	5.42	9.13	6.11	9.65	4.92	1.23	16.8	15.0	3/4" FPT	16 × 25 × 1
LV030	22.0	43.0	18.0	1.5	25.0	16.5	2.47	15.0	5.42	9.13	6.11	9.65	4.92	1.23	16.8	15.0	3/4" FPT	16 × 25 × 1

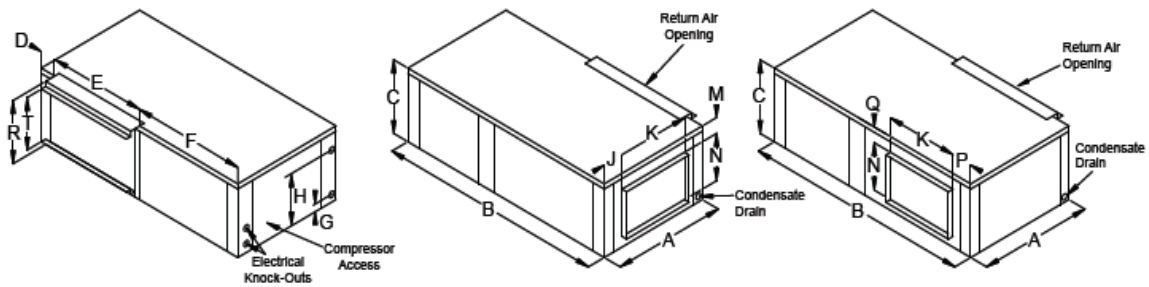

Left Hand Return End Blow (FLE)

Left Hand Return Straight Through (FLS)

NOTE: Models LV048 & 060 Left Hand Return units have condenser water connections on the front right and electrical knockouts on the front left.

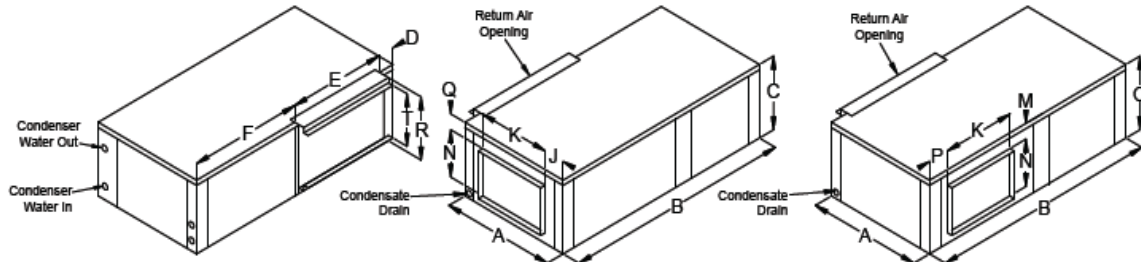

Right Hand Return End Blow (FRE)

Right Hand Return Straight Through (FRS)

Service Clearances

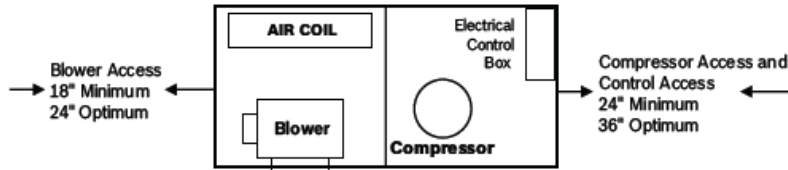

NOTE: The local electric codes may require 36" or more clearance at the electrical control box. Subject to change without prior notice.

Figure #2 – LV Horizontal Cabinet Dimensions

*

NOTE: All dimensions within +0.125". All condensate drain connections are 3/4" FPT. LV015-070 can be field converted between end blow and straight thru supply air configurations. 1" filter rack extends 1.23" beyond

the side of the unit. 2" filter rack extends 2.89" beyond the side of the unit. The 2" filter rack is 4 sided with filter access door on one end and can accept either a 1" or 2" filter.

OVERLOAD SETTING VERIFICATION:

Thermal Overload Relays are used on 036-1 PSC & EON blower equipped units and all 036-2 units. Prior to energizing these units, visually verify the amperage setting of the overload relay is set as defined below in Figures #3 - 5.

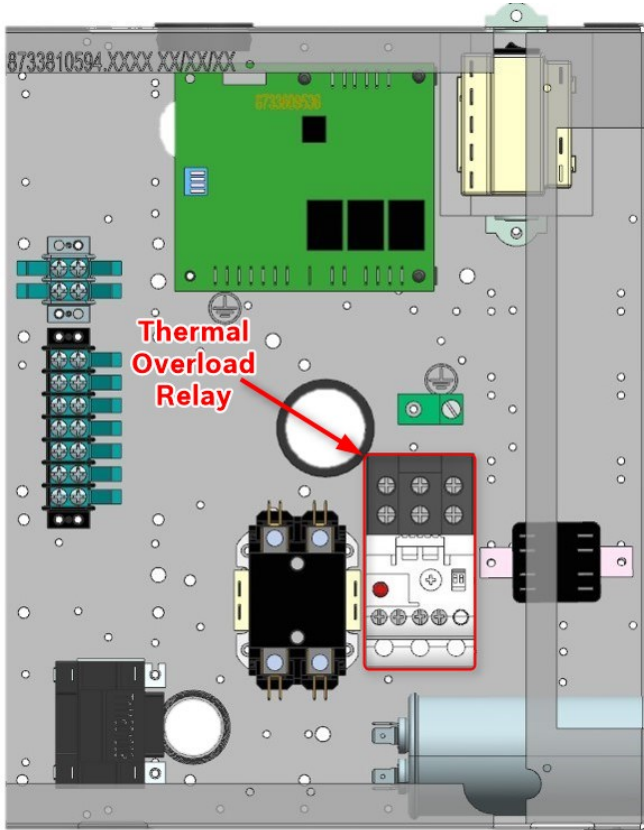

Figure #3 – Overload Relay E-Box Mounting Location

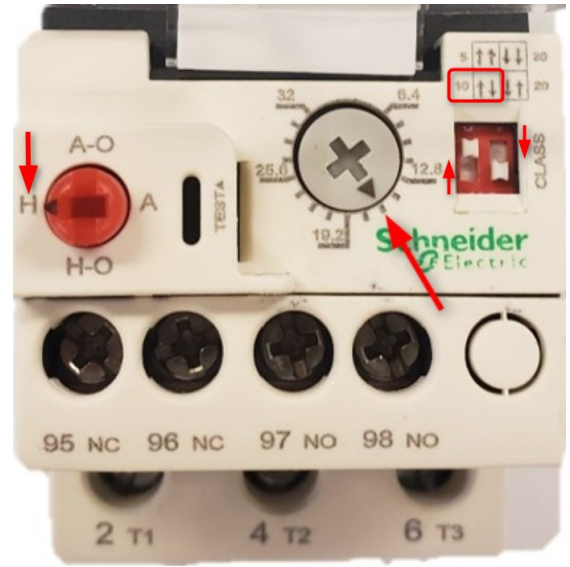

Figure #4 – 036-1 PSC & EON Units Overload Settings

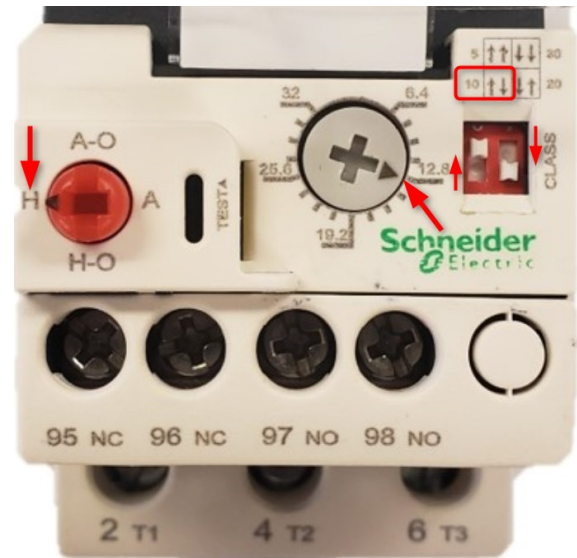

Figure #5 – 036-2 Units Overload Settings

Notes:

Notes:

Notes: